

AT7020 Series

Multilayer Chip Antenna

Features

- ❖ Monolithic SMD with small, low-profile and light-weight type.
- ❖ Wide bandwidth
- ❖ RoHS compliant



Applications

- ❖ 2.4GHz WLAN, Home RF, Bluetooth Modules, etc.

Specifications

Part Number	Operating Frequency (MHz)	Peak Gain (dBi typ.)	Average Gain (dBi typ.)	VSWR	Impedance
AT7020 -A2R4HAA_	2400~2500	3.0 (3D Total)	-1.6 (3D Total)	2 max.	50 Ω

Q'ty/Reel (pcs) : 1,000 pcs
 Operating Temperature Range : -40 ~ +85 °C
 Storage Temperature Range : -40 ~ +85 °C
 Storage Period : 12 months max.
 Power Capacity : 2W max.

Part Number

AT **7020** - **A** **2R4** **HAA** **□**
 ① ② ③ ④ ⑤ ⑥

① Type	AT : Antenna	② Dimensions (L × W)	7.0× 2.0 mm
③ Material Code	A	④ Initial center frequency	2R4=2400MHz
⑤ Specification Code	HAA	⑥ Packaging	T: Tape & Reel B: Bulk

Terminal Configuration

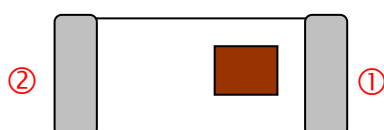

No.	Terminal Name	No.	Terminal Name
①	Feeding Point	②	NC

Dimensions and Recommended PC Board Pattern

Unit : mm

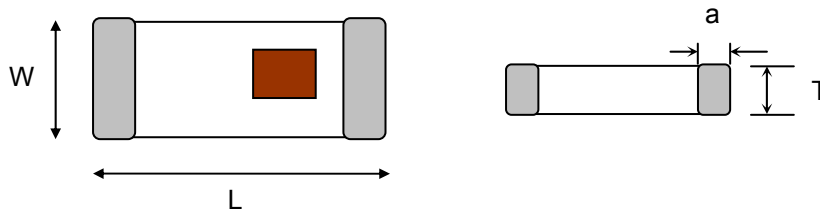

Mark	L	W	T	a
Dimensions	7.0±0.2	2.0±0.2	1.2+ 0.1/-0.2	0.5±0.3

(a) AT7020-A2R4HAA (Vertical) with Matching Circuits

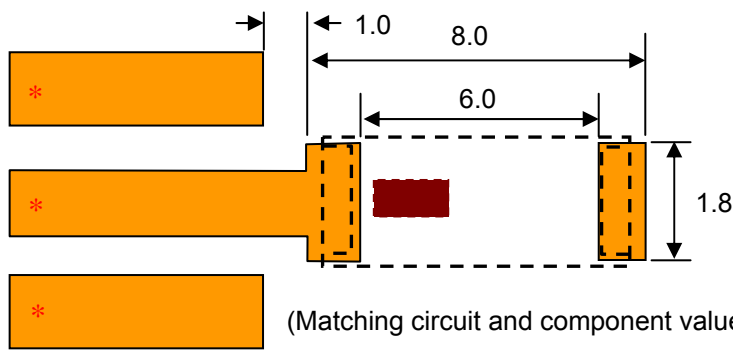

(Matching circuit and component values will be different, depending on PCB layout)

* Line width should be designed to match 50Ω characteristic impedance, depending on PCB material and thickness.

(b) AT7020-A2R4HAA (Horizontal) with Matching Circuits

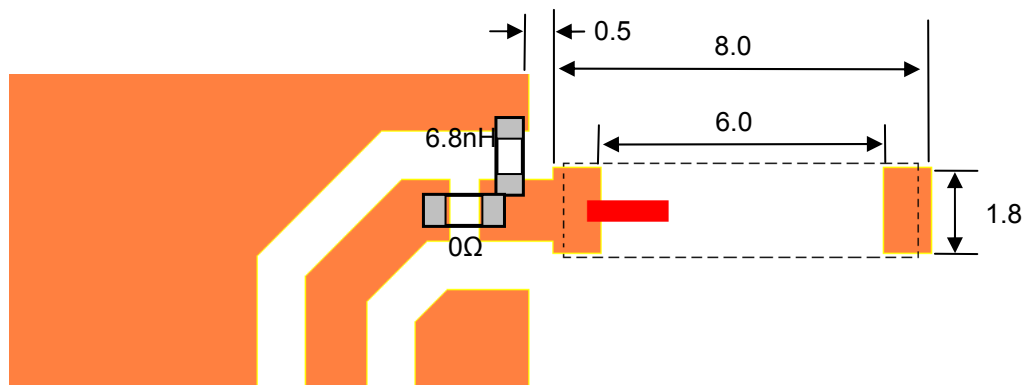

(Matching circuit and component values will be different, depending on PCB layout)

* Line width should be designed to match 50Ω characteristic impedance, depending on PCB material and thickness.

Typical Electrical Characteristics (T=25°C)

❖ Test Board Type-A (AT7020-V)

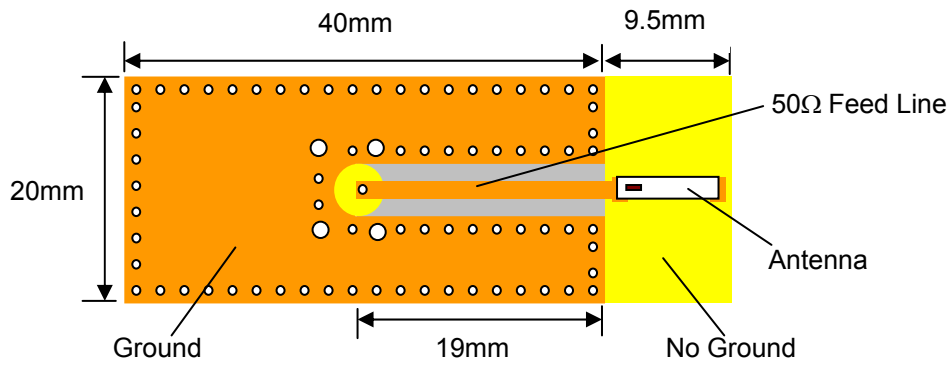

❖ Return Loss

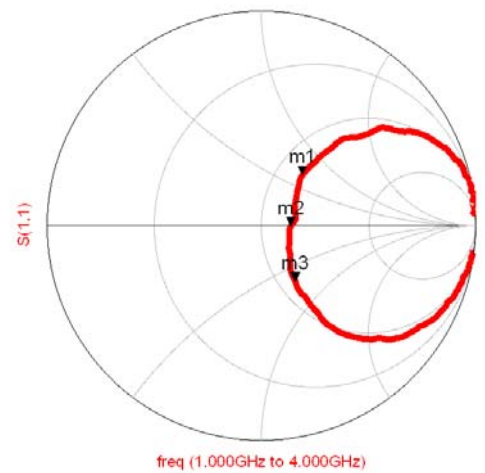
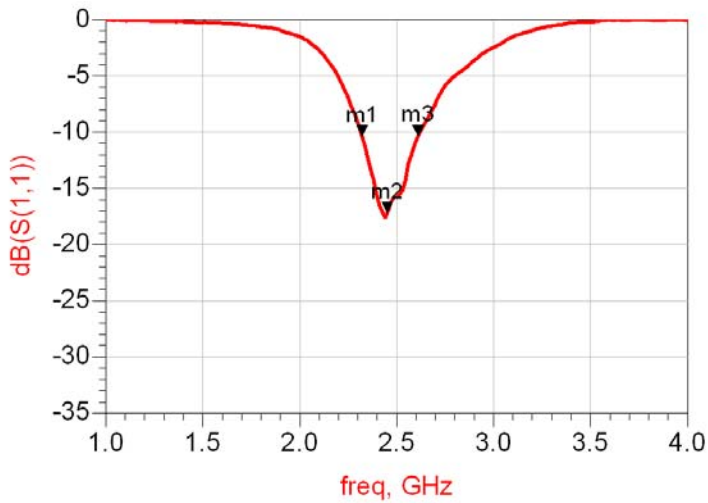

❖ Radiation Patterns

(Antenna Efficiency: 2400 / 2450 / 2500MHz: 71 / 69 / 77%)

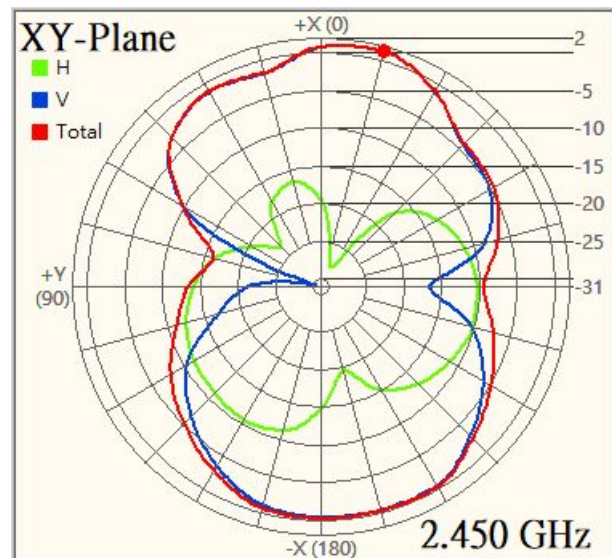
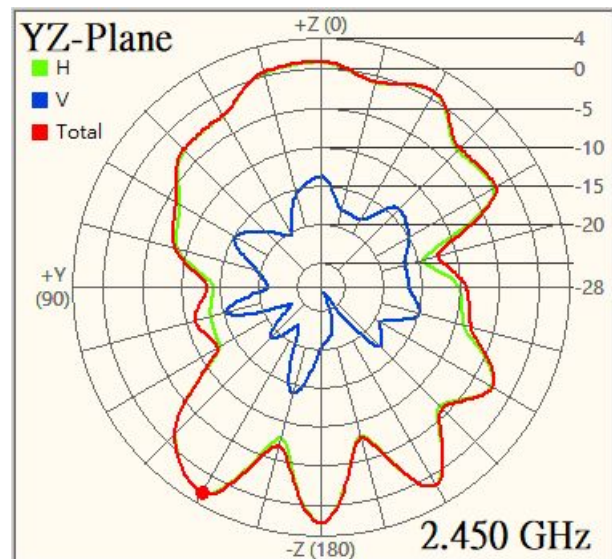
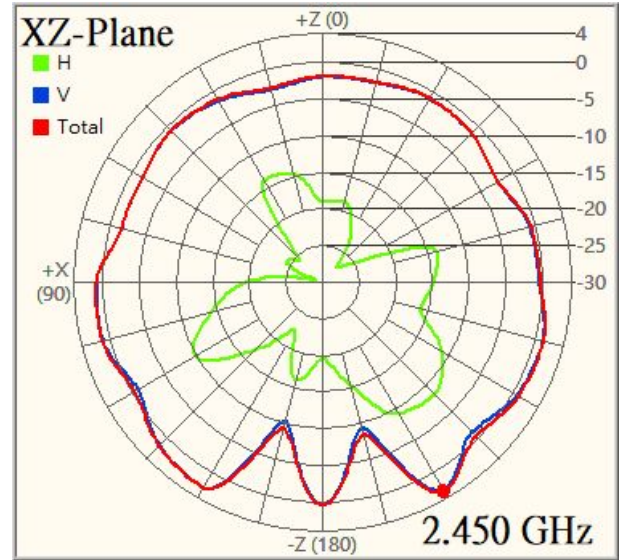
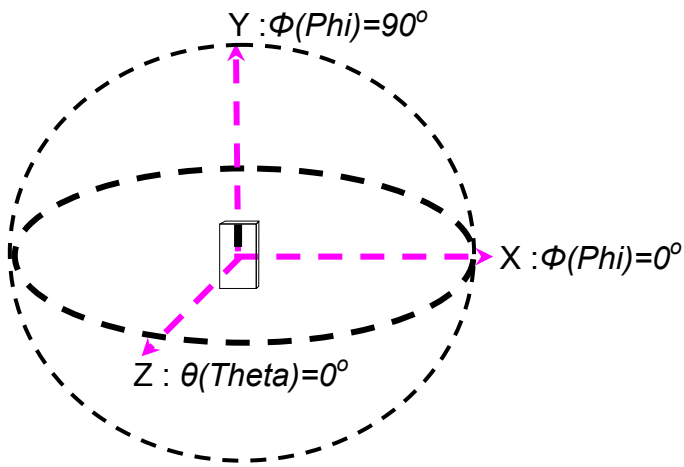

❖ Test Board Type-B (AT7020-H2)

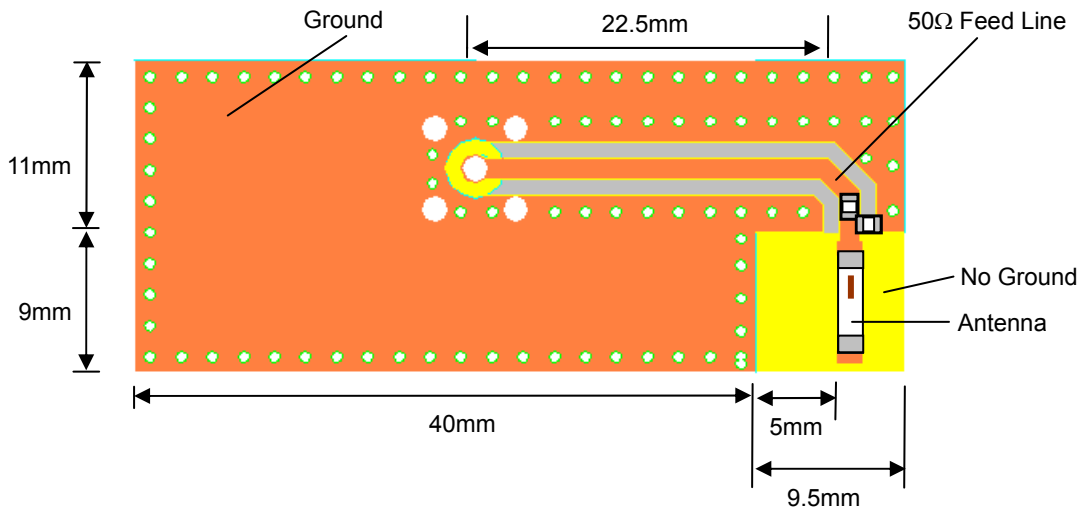

❖ Return Loss (with matching circuit)

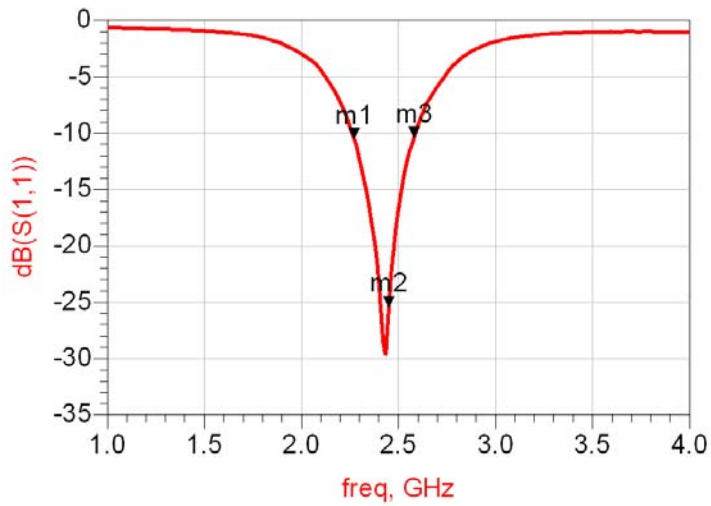

m1	freq=2.270GHz	dB(S(1,1))=-10.484
m2	freq=2.450GHz	dB(S(1,1))=-25.420
m3	freq=2.580GHz	dB(S(1,1))=-10.370

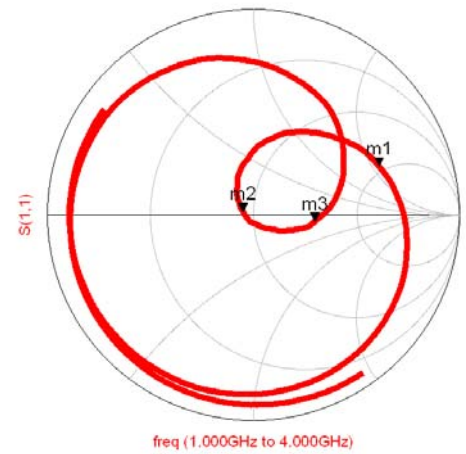

❖ Radiation Patterns

(Antenna Efficiency: 2400 / 2450 / 2500MHz: 70 / 66 / 71%)

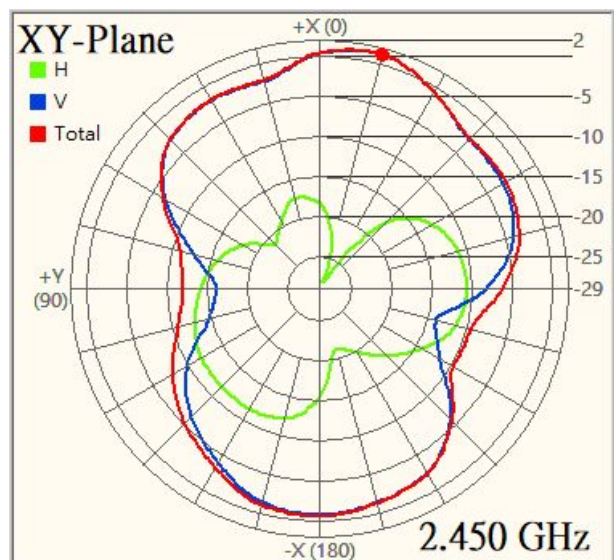
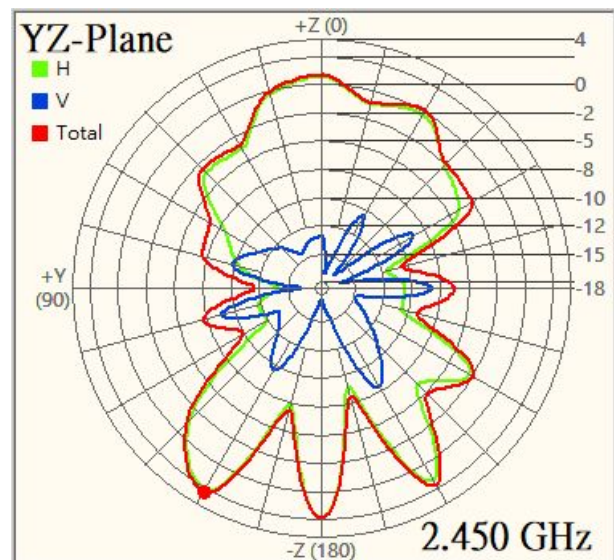
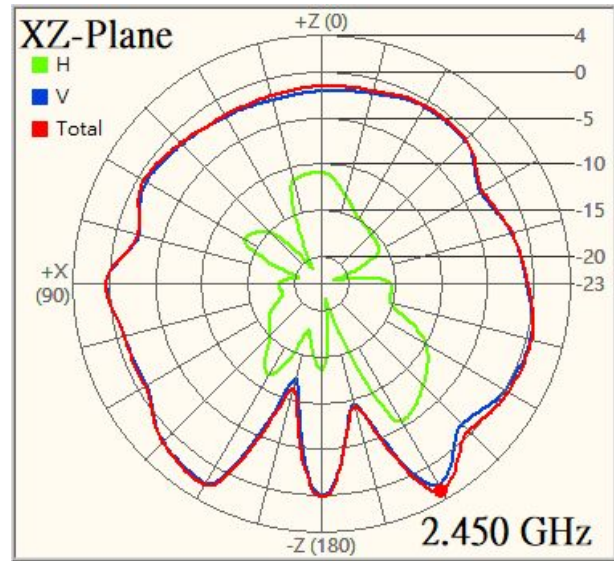
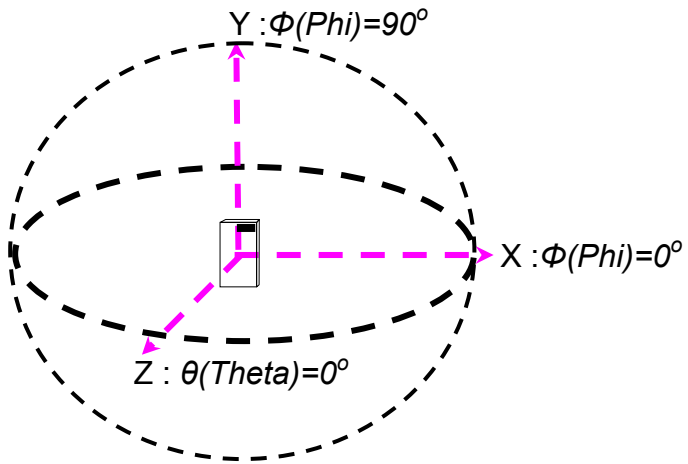

Taping Specifications

❖Tape & Reel Dimensions (Unit: mm) vs. Quantity (pcs)

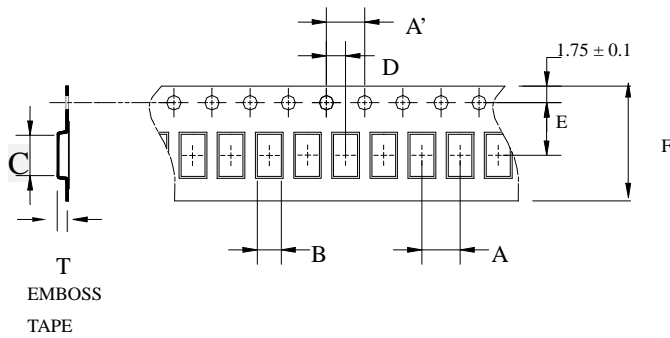

Type	A	A'	B	C	D	E	F	T	Quantity/per reel	Tape material
AT7020	4.0±	4.0±	2.4±	7.3±	2.0±	5.5±	12.0±	1.45±	1,000pcs	Plastic (Embossed)
	0.1	0.1	0.1	0.1	0.05	0.1	0.1	0.1		

❖Reel Dimensions (Unit: mm)

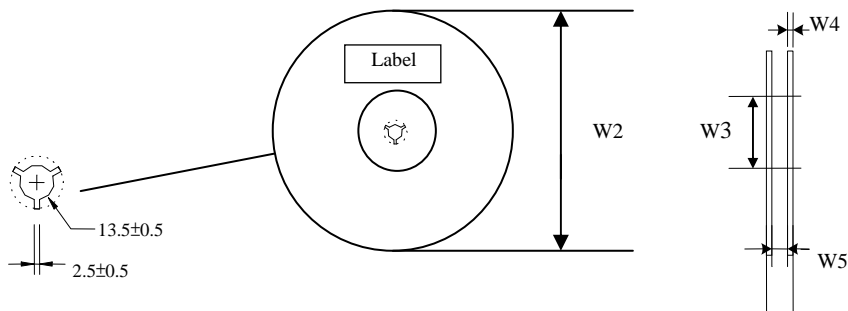

Label: Customer's Name,
ACX P/N, Q'ty, Date,
ACX Corp.

Type	W2	W3	W4	W5
AT5020	178±1	60±0.5	1.485±0.5	13±0.5

❖Leader and Trailer Tape

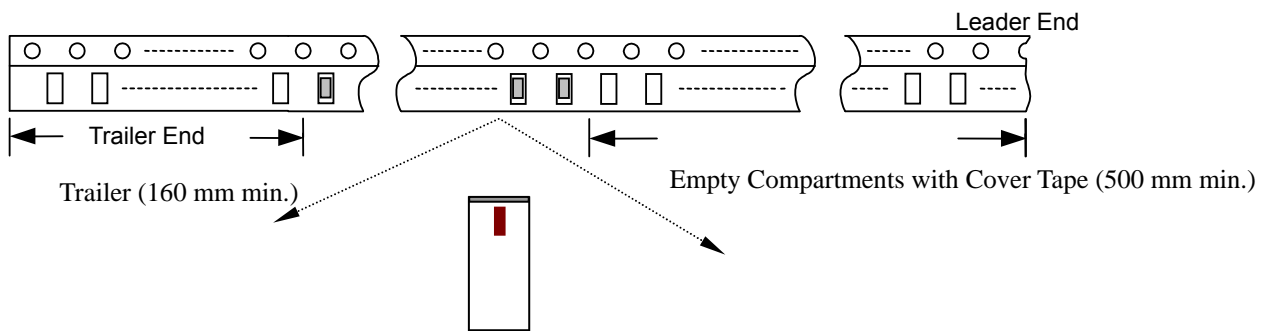

❖ **Peel-off Force**

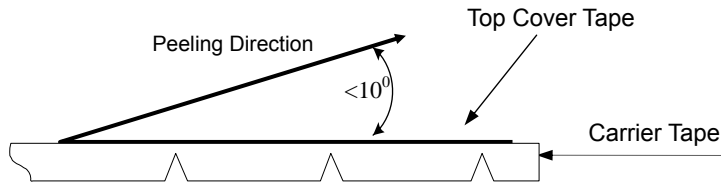

Peel-off force should be in the range of 0.2 – 1.20 N at a peel-off speed of 300 ± 10 mm/min .

❖ **Storage Conditions**

- (1) Temperature: 5 ~35°C , relative humidity (RH): 45~75%.
- (2) Non-corrosive environment.

Notes

❖ The contents of this data sheet are subject to change without notice. Please confirm the specifications and delivery conditions when placing your order.

Mechanical & Environmental Characteristics

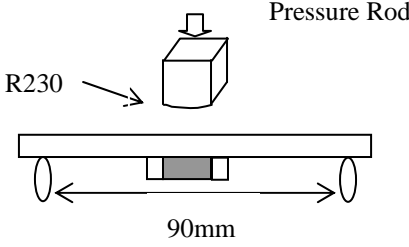
Item	Requirements	Procedure
Solderability	<ol style="list-style-type: none"> No apparent damage More than 95% of the terminal electrode shall be covered with new solder 	<ol style="list-style-type: none"> Preheat: $120 \pm 5^\circ\text{C}$ Solder: $245 \pm 5^\circ\text{C}$ for 5 ± 1 sec
Soldering strength (Termination Adhesion)	<ol style="list-style-type: none"> 10N minimum 	<ol style="list-style-type: none"> Solder specimen onto test jig. Apply push force at 0.5mm/s until electrode pads are peeled off or ceramic are broken. Pushing force is applied to longitude direction.
Deflection (Substrate Bending)	<ol style="list-style-type: none"> No apparent damage 	<ol style="list-style-type: none"> Solder specimen onto test jig (FR4, 1.6mm) using the recommend soldering profile. Apply a bending force of 1mm deflection. 
Heat/Humidity Resistance	<ol style="list-style-type: none"> No apparent damage Fulfill the electrical specification after test 	<ol style="list-style-type: none"> Temperature: $85 \pm 2^\circ\text{C}$ Humidity: 90% ~ 95% RH Duration: 1000 ± 48hrs Recovery: 1-2hrs
Thermal shock (Temperature Cycle)	<ol style="list-style-type: none"> No apparent damage Fulfill the electrical specification after test 	<ol style="list-style-type: none"> One cycle/step 1 : $125 \pm 5^\circ\text{C}$ for 30 min step 2 : $-40 \pm 5^\circ\text{C}$ for 30 min No of cycles : 100 Recovery: 1-2 hrs
Low Temperature Resistance	<ol style="list-style-type: none"> No apparent damage Fulfill the electrical specification after test 	<ol style="list-style-type: none"> Temperature: $-40 \pm 5^\circ\text{C}$ Duration: 500 ± 24hrs Recovery: 1-2hrs

Soldering Conditions

❖ Typical Soldering Profile for Lead-free Process

Reflow Soldering :

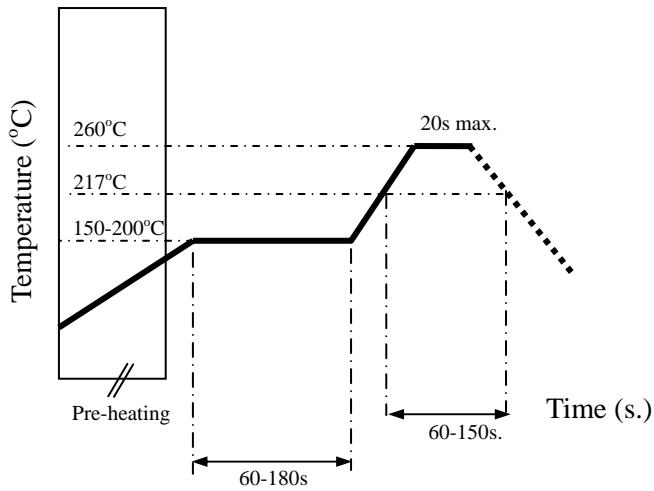

Notes

❖ The contents of this data sheet are subject to change without notice. Please confirm the specifications and delivery conditions when placing your order.

Advanced Ceramic X Corp.

16 Tzu Chiang Road, Hsinchu Industrial District Hsinchu Hsien 303, Taiwan

TEL:886-3-5987008 FAX:886-3-5987001

E-mail: acx@acxc.com.tw

<http://www.acxc.com.tw>