

ATR240 Series **[Preliminary]**

Multilayer Chip Antenna



Features

- ❖ Monolithic SMD with small, low-profile and light-weight type.
- ❖ Wide bandwidth

Applications

- ❖ Low power radio applications for 868MHz.

Specifications

Part Number	Operating Frequency (MHz)	Peak Gain (dBi typ.)	Average Gain (dBi typ.)	VSWR	Impedance
ATR240-TR86HCA_	858~878	1.0 (XY-Total)	-2.0 (XY-Total)	3.0 max.	50 Ω

Q'ty/Reel (pcs) : 500 pcs
 Operating Temperature Range : -40 ~ +85 °C
 Storage Temperature Range : -40 ~ +85 °C
 Storage Period : 12 months max.
 Power Capacity : 2W max.

Part Number

AT **R240** - **T** **R86** **HCA** **□** **/LF**
 ① ② ③ ④ ⑤ ⑥ ⑦

① Type	AT : Antenna	② Dimensions (L x W)	15.0x 4.0 mm
③ Material Code	T	④ Initial center frequency	R86=868MHz
⑤ Specification Code	HCA	⑥ Packaging	T: Tape & Reel B: Bulk
⑦ Soldering	=lead-containing /LF=lead-free		

Terminal Configuration

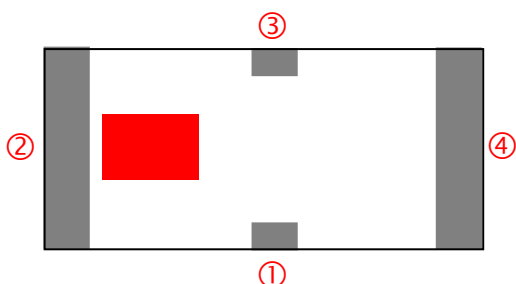

No.	Terminal Name	No.	Terminal Name
①	NC	③	NC
②	Feeding point	④	GND

Dimensions and Recommended PC Board Pattern

Unit : mm

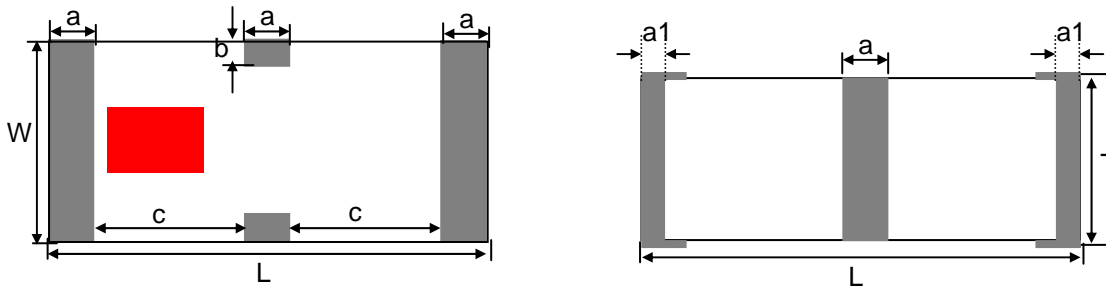

Mark	L	W	T	a	a1	b	c
Dimensions	15.0±0.2	4.0±0.2	3.2±0.2	1.0±0.2	0.5±0.2	0.5±0.2	6.0±0.2

❖ Without Matching Circuits (Unit in mm)

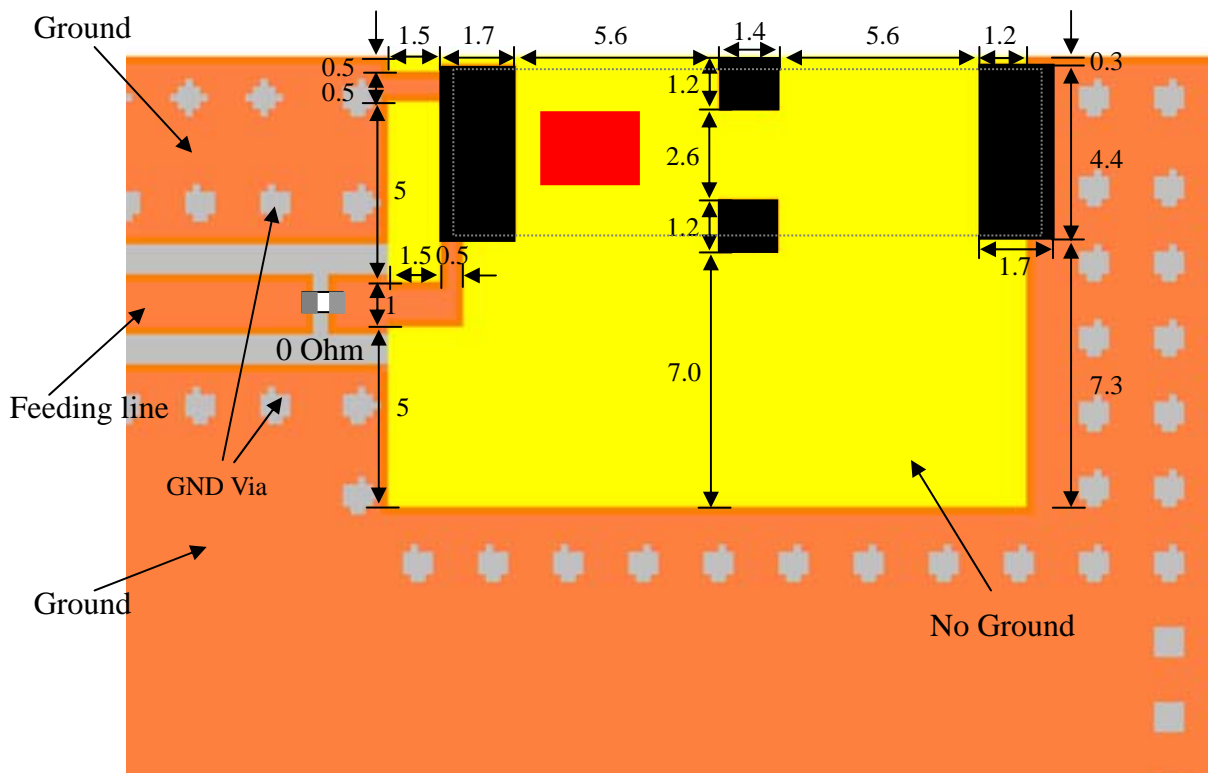

(Matching circuit and component values will be different, depending on PCB layout)

Orange Solder Resist

Black Land

*Line width should be designed to match 50Ω characteristic impedance, depending on PCB material and thickness.

Typical Electrical Characteristics (T=25°C)

❖ Test Board-Top View (Unit in mm)

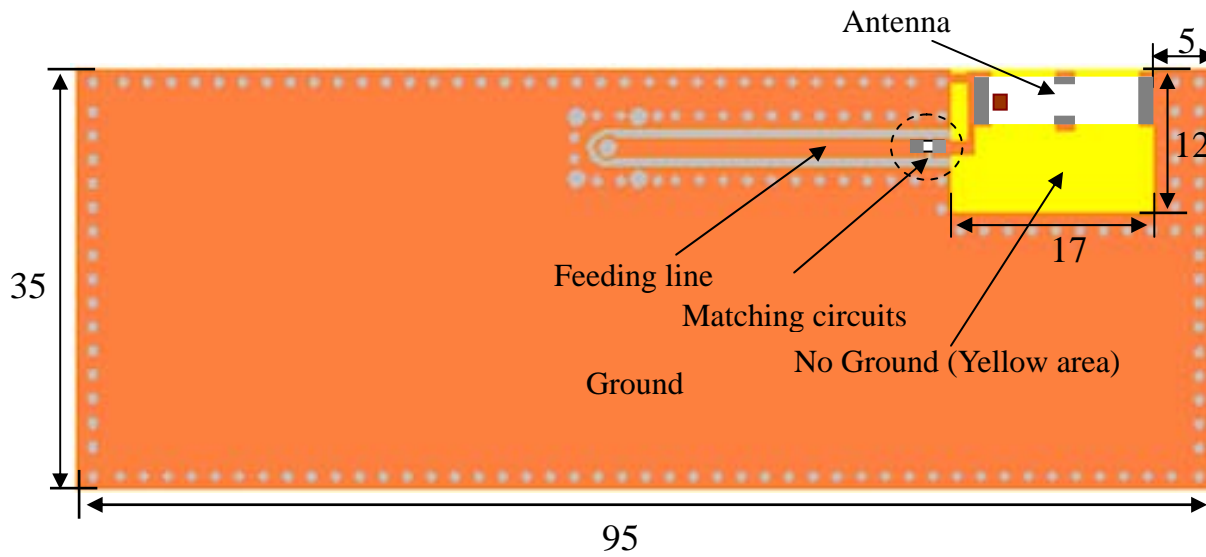

❖ Test Board-Bottom View (Unit in mm)

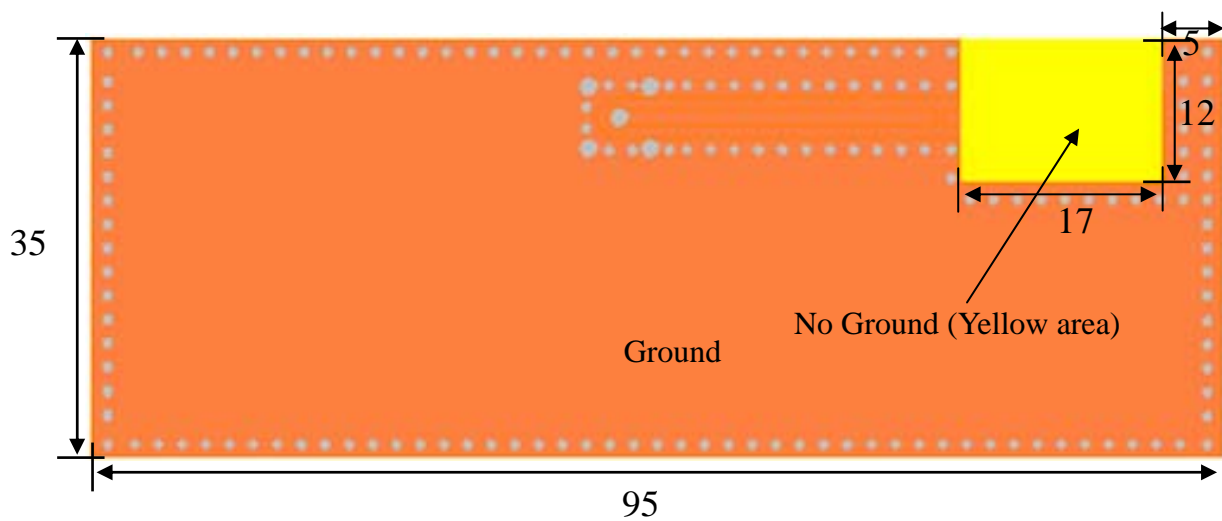

❖ Return Loss / Without Matching Circuits

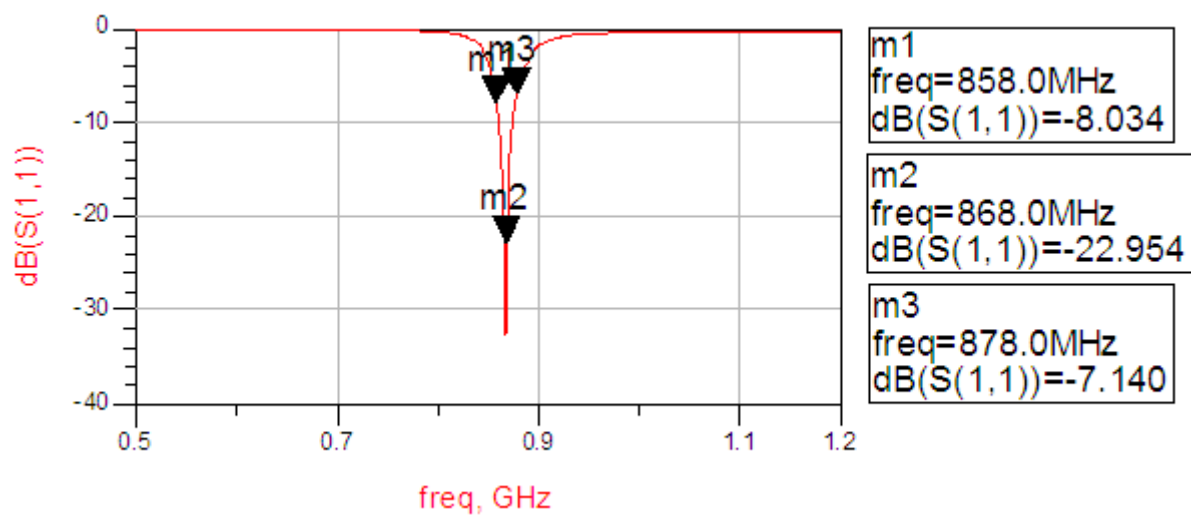

❖ Radiation Patterns

XY cut @ 868MHz
Vertical
Horizontal

XY-V/XY-H

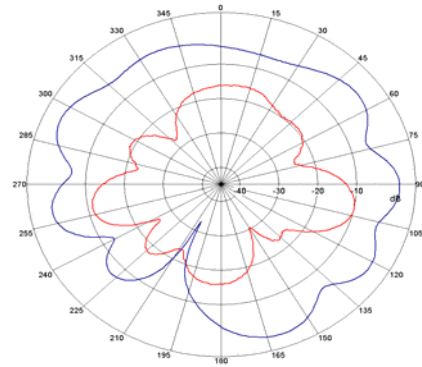
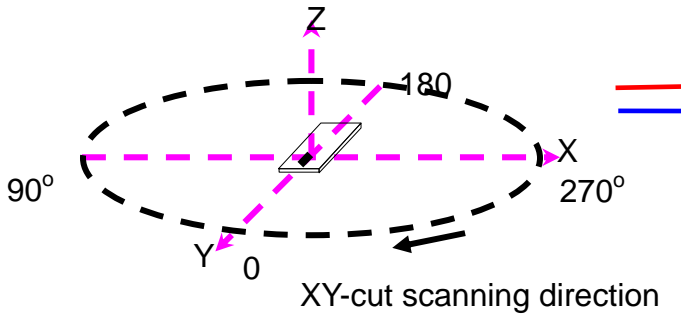

XZ-V/XZ-H

XZ cut @ 868MHz
Vertical
Horizontal

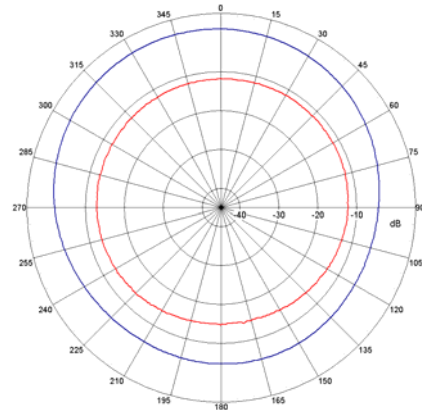
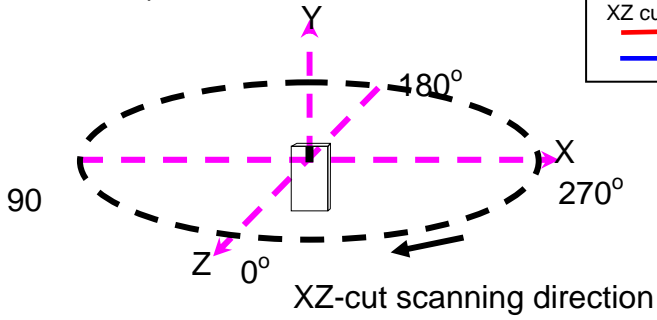

YZ-V/YZ-H

YZ cut @ 868MHz
Vertical
Horizontal

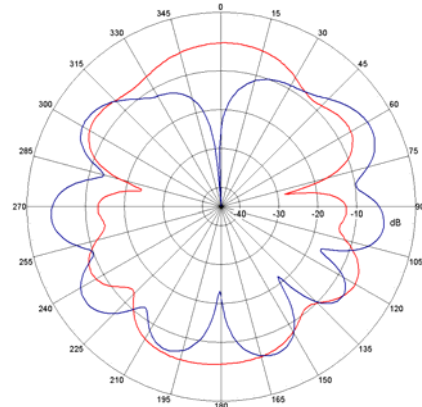
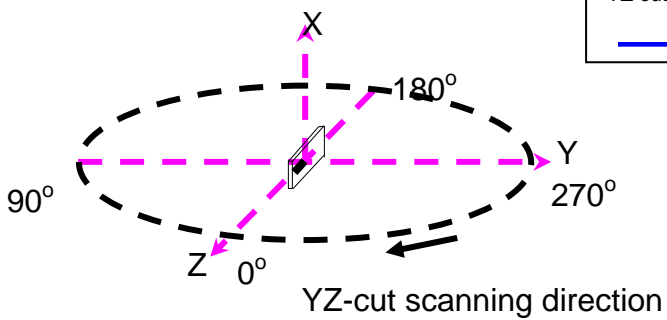

Taping Specifications

❖Tape & Reel Dimensions (Unit: mm) vs. Quantity (pcs)

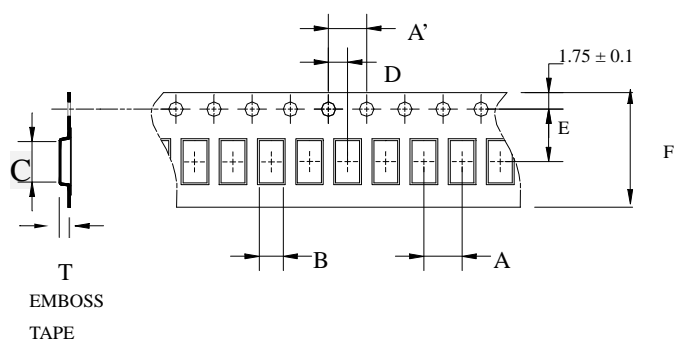

Type	A	A'	B	C	D	E	F	T	Quantity/per reel	Tape material
ATR240	8.0±	4.0±	4.35±	15.4±	2.0±	11.5±	24.0±	3.50±	500pcs	Plastic (Embossed)
	0.1	0.1	0.1	0.1	0.1	0.1	0.3	0.1		

❖Reel Dimensions (Unit: mm)

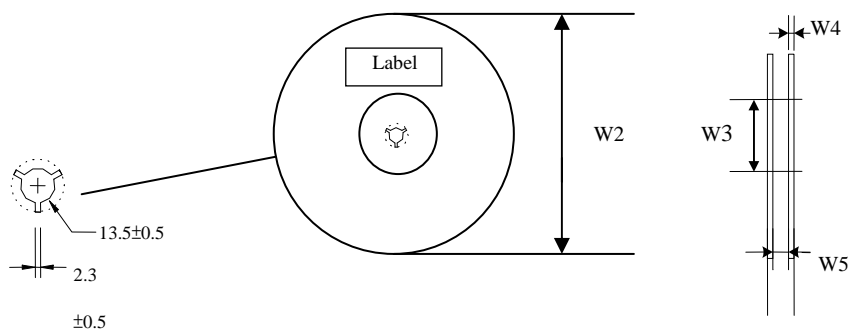

Label: Customer's Name,
ACX P/N, Q'ty, Date,
ACX Corp.

Type	W2	W3	W4	W5
ATR240	330±2	178±2	2.0±0.2	45±0.5

❖Leader and Trailer Tape

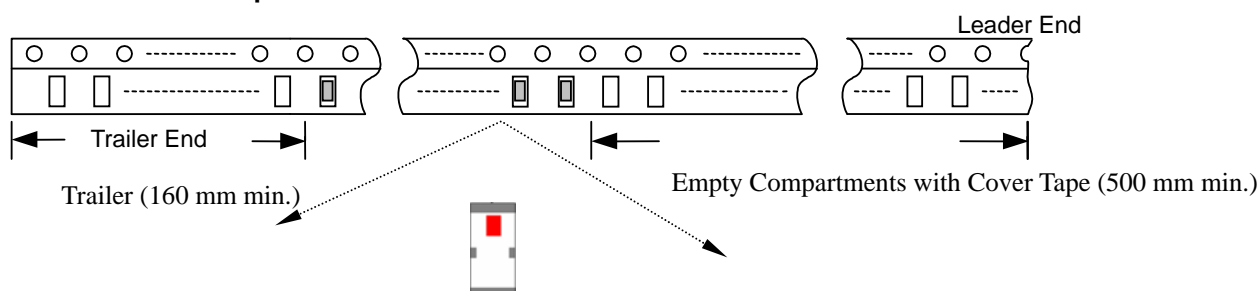

❖ **Peel-off Force**

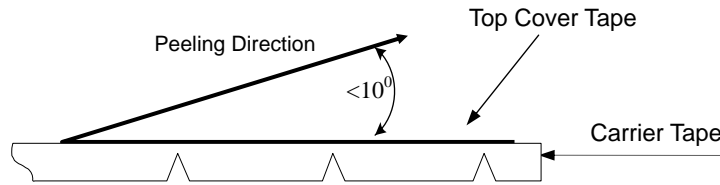

Peel-off force should be in the range of 0.2 – 1.20 N at a peel-off speed of 300 ± 10 mm/min .

❖ **Storage Conditions**

- (1) Temperature: 5 ~35°C , relative humidity (RH): 45~75%.
- (2) Non-corrosive environment

Notes

❖ The contents of this data sheet are subject to change without notice. Please confirm the specifications and delivery conditions when placing your order.

Mechanical & Environmental Characteristics

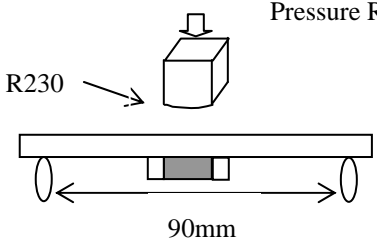
Item	Requirements	Procedure
Solderability	<ol style="list-style-type: none"> No apparent damage More than 95% of the terminal electrode shall be covered with new solder 	<ol style="list-style-type: none"> Preheat: $120 \pm 5^\circ\text{C}$ Solder: $245 \pm 5^\circ\text{C}$ for 5 ± 1 sec
Soldering strength (Termination Adhesion)	<ol style="list-style-type: none"> 1kg minimum 	<ol style="list-style-type: none"> Solder specimen onto test jig. Apply push force at 0.5mm/s until electrode pads are peeled off or ceramic are broken. Pushing force is applied to longitude direction
Deflection (Substrate Bending)	<ol style="list-style-type: none"> No apparent damage 	<ol style="list-style-type: none"> Solder specimen onto test jig (FR4, 0.8mm) using the recommend soldering profile. Apply a bending force of 1mm deflection 
Heat/Humidity Resistance	<ol style="list-style-type: none"> No apparent damage Fulfill the electrical specification after test 	<ol style="list-style-type: none"> Temperature: $85 \pm 2^\circ\text{C}$ Humidity: 90% ~ 95% RH Duration: 1000 ± 48hrs Recovery: 1-2hrs
Thermal shock (Temperature Cycle)	<ol style="list-style-type: none"> No apparent damage Fulfill the electrical specification after test 	<ol style="list-style-type: none"> One cycle/step 1 : $125 \pm 5^\circ\text{C}$ for 30 min step 2 : $-40 \pm 5^\circ\text{C}$ for 30 min No of cycles : 100 Recovery: 1-2 hrs
Low Temperature Resistance	<ol style="list-style-type: none"> No apparent damage Fulfill the electrical specification after test 	<ol style="list-style-type: none"> Temperature: $-40 \pm 5^\circ\text{C}$ Duration: 500 ± 24hrs Recovery: 1-2hrs

Soldering Conditions

❖ Typical Soldering Profile for Lead-free Process

Reflow Soldering :

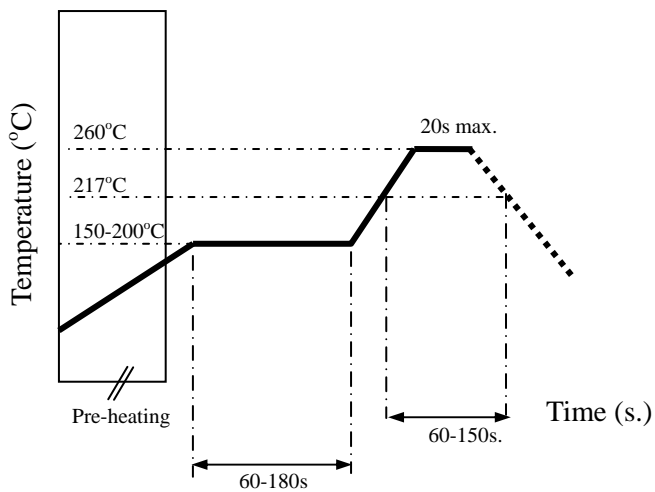

Notes

❖ The contents of this data sheet are subject to change without notice. Please confirm the specifications and delivery conditions when placing your order.

Advanced Ceramic X Corp.

16 Tzu Chiang Road, Hsinchu Industrial District Hsinchu Hsien 303, Taiwan

TEL:886-3-5987008 FAX:886-3-5987001

E-mail: acx@acxc.com.tw

<http://www.acxc.com.tw>