

# DP 1608 Series

## Multilayer Chip Diplexers

### Features

- ❖ Monolithic structure including one low-pass and one band-pass filters with loss pole at adjacent passband.
- ❖ RoHS compliant.

### Applications

- ❖ Dual-band / dual-mode 2.5GHz/6.1GHz WLAN.

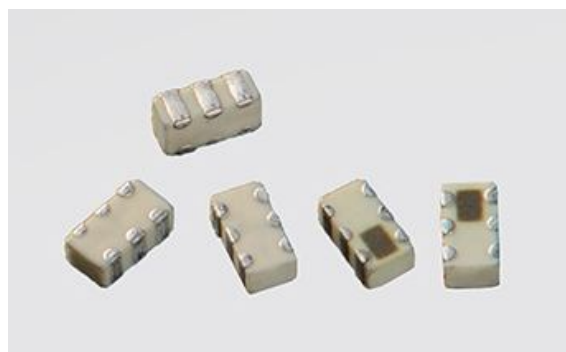

### Specifications

Part Number	Passband (MHz)	Insertion Loss (dB)	Return Loss (dB)	Attenuation (dB)
DP1608-R2461AL	2400~2500	0.6 max. @25 °C 0.8 max. @-40~+105 °C	12 min.	2 min. @3300~4800MHz 33 min. @4800~5000MHz 25 min. @5170~7125MHz 25 min. @7200~7500MHz 27 min. @9600~10000MHz 20 min. @12000~12500MHz
	5170~7125	0.9 max. @25 °C 1.15 max. @-40~+105 °C	10 min.	35 min. @70~108MHz 35 min. @700~915MHz 15 min. @915~960MHz 30 min. @1425~1470MHz 28 min. @1470~1557MHz 26 min. @1557~1607MHz 35 min. @1710~1785MHz 26 min. @1805~1850MHz 35 min. @1850~1910MHz 35 min. @1910~2020MHz 23 min. @2110~2200MHz 26 min. @2300~2400MHz 25 min. @2400~2500MHz 20 min. @2500~2690MHz 10 min. @3400~3800MHz 25 min. @10340~14250MHz 30 min. @15510~19500MHz 22 min. @19500~21375MHz

Q'ty/Reel (pcs) : 4000  
 Operating Temperature Range : -40 ~ +105 °C  
 Storage Temperature Range : -40 ~ +105 °C  
 Storage Period : 12 months max.  
 Power Capacity : 3W max.

## Part Number

DP   1608   -   R   2461   AL   □   /LF  
 ①   ②   ③   ④   ⑤   ⑥   ⑦

① Type	DP : Diplexer	② Dimensions ( L × W )	1.6 × 0.8 mm
③ Material Code	R	④ Frequency Range	2461=2450MHz /6150MHz
⑤ Specification Code	AL	⑥ Packaging	T: Tape & Reel B: Bulk
⑦ Soldering	/LF=lead-free		

## Terminal Configuration

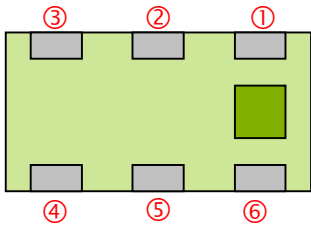

No.	Terminal Name	No.	Terminal Name
①	GND	④	Higher Freq. Port
②	Common Port	⑤	GND
③	GND	⑥	Lower Freq. Port

## Dimensions and Recommended PC Board Pattern

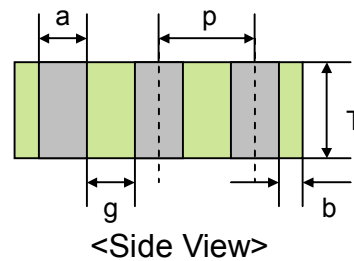
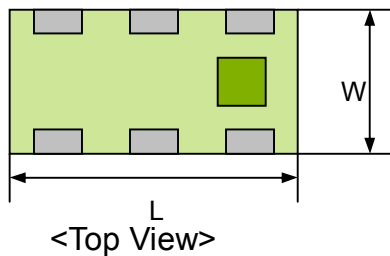

Unit : mm

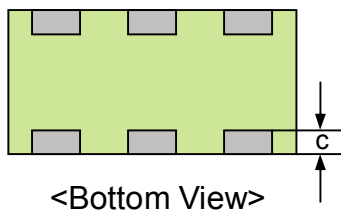

Mark	L	W	T	a	b	c	g	p
Dimensions	1.6±0.1	0.8±0.1	0.7max.	0.2±0.1	0.2+0.1 /-0.15	0.15±0.1	0.3±0.1	0.5±0.05

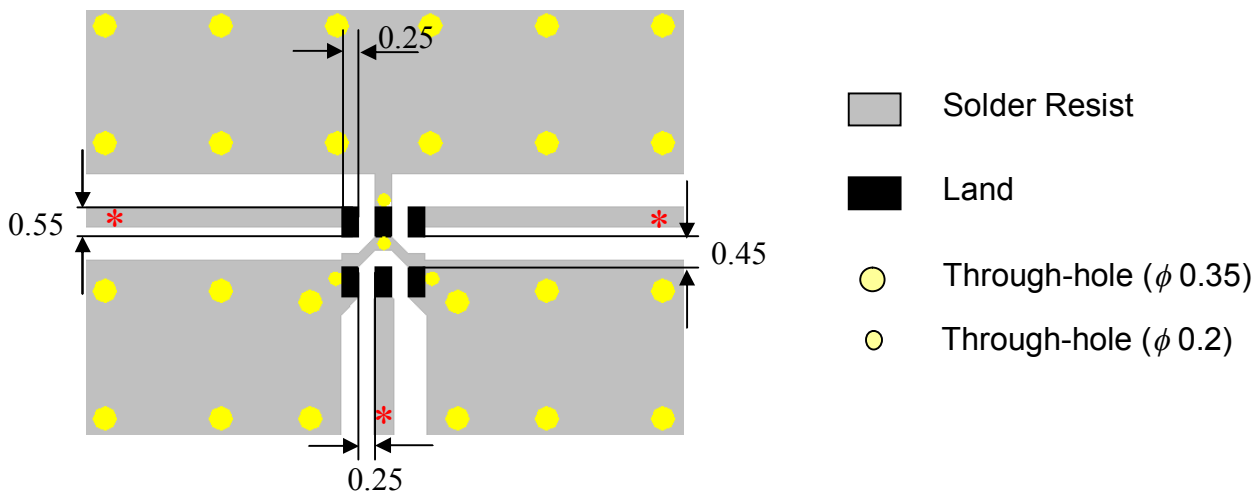

\* Line width should be designed to match 50ohm characteristic impedance, depending on PCB material and thickness.

## Measuring Diagram

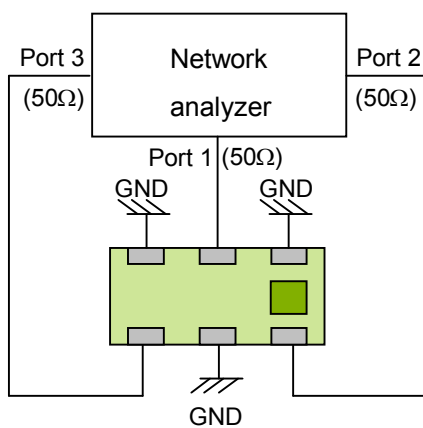

**Typical Electrical Characteristics (T=25°C)**

**Attenuation**

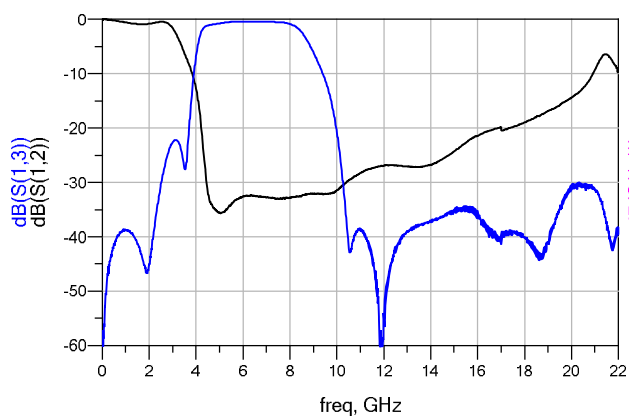

**Return Loss**

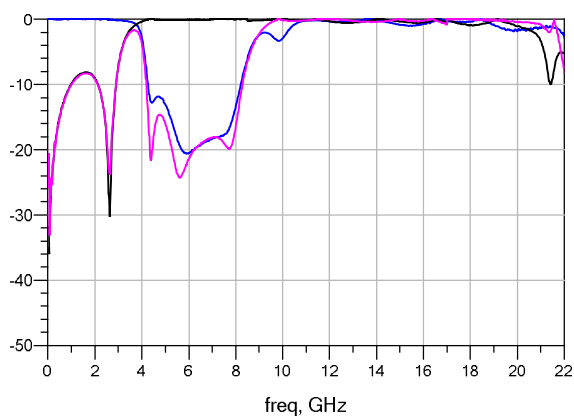

**Notes**

❖ The contents of this data sheet are subject to change without notice. Please confirm the specifications and delivery conditions when placing your order.

## Taping Specifications

### ❖Tape Dimensions (Unit: mm) & Quantity

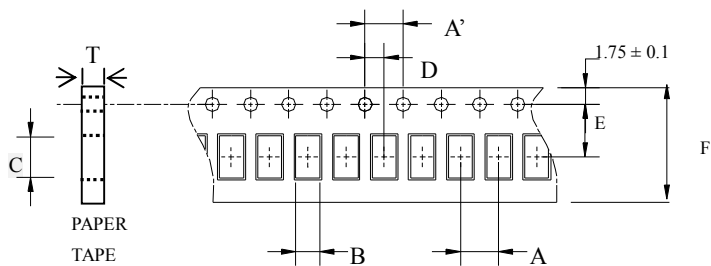

Type	A	A'	B	C	D	E	F	T	Quantity/reel	Tape material
1608	4.0±	4.0±	1.10±	1.92±	2.0±	3.5±	8.0±	0.80±	4,000pcs	Paper
	0.10	0.10	0.05	0.05	0.05	0.05	0.10	0.05		

### ❖Reel Dimensions (Unit: mm)

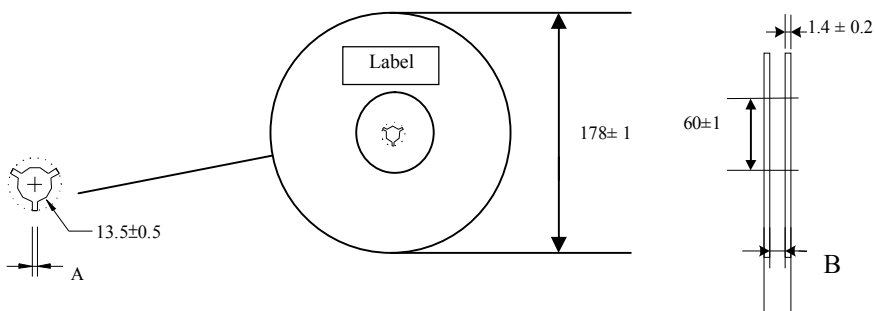

Label: Customer's Name,  
ACX P/N, Q'ty, Date,  
ACX Corp.

Type	A	B
1608	2.3±0.5	9.0±0.3

### ❖Leader and Trailer Tape

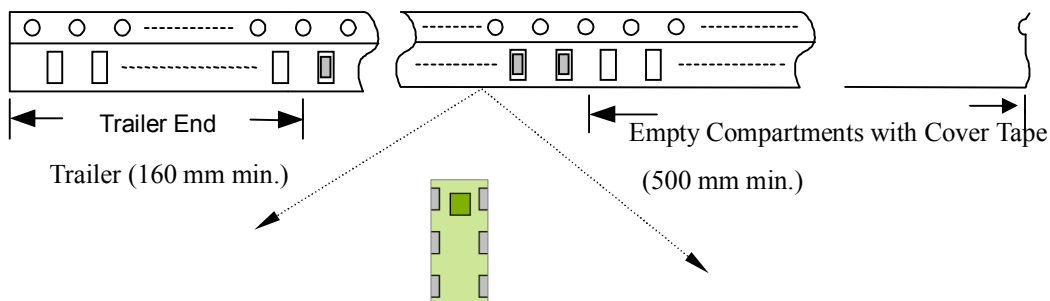

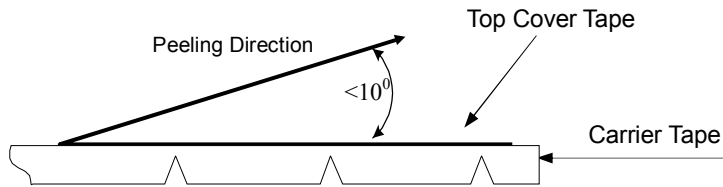
**❖Peel-off Force**

Peel-off force should be in the range of 0.1 – 0.6 N at a peel-off speed of  $300\pm 10$  mm/min .

**❖Storage Conditions**

- (1) Temperature:  $5 \sim 35^{\circ}\text{C}$  , relative humidity (RH): 45~75%.
- (2) Non-corrosive environment.

**Notes**

- ❖The contents of this data sheet are subject to change without notice. Please confirm the specifications and delivery conditions when placing your order.

## Mechanical & Environmental Characteristics

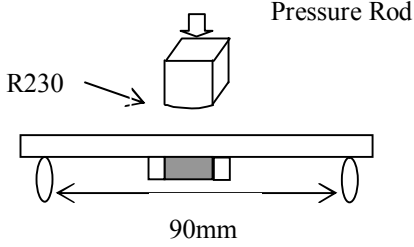
Item	Requirements	Procedure
Solderability	<ol style="list-style-type: none"> <li>No apparent damage</li> <li>More than 95% of the terminal electrode shall be covered with new solder</li> </ol>	<ol style="list-style-type: none"> <li>Preheat: <math>120 \pm 5^\circ\text{C}</math></li> <li>Solder: <math>245 \pm 5^\circ\text{C}</math> for <math>5 \pm 1</math> sec</li> </ol>
Soldering strength (Termination Adhesion)	<ol style="list-style-type: none"> <li>10N minimum</li> </ol>	<ol style="list-style-type: none"> <li>Solder specimen onto test jig.</li> <li>Apply push force at 0.5mm/s until electrode pads are peeled off or ceramic are broken. Pushing force is applied to longitude direction</li> </ol>
Deflection (Substrate Bending)	<ol style="list-style-type: none"> <li>No apparent damage</li> </ol>	<ol style="list-style-type: none"> <li>Solder specimen onto test jig (FR4, 1.6mm) using the recommend soldering profile.</li> <li>Apply a bending force of 2mm deflection</li> </ol> 
Heat/Humidity Resistance	<ol style="list-style-type: none"> <li>No apparent damage</li> <li>Fulfill the electrical specification after test</li> </ol>	<ol style="list-style-type: none"> <li>Temperature: <math>85 \pm 2^\circ\text{C}</math></li> <li>Humidity: 90% ~ 95% RH</li> <li>Duration: <math>1000 \pm 48</math>hrs</li> <li>Recovery: 1-2hrs</li> </ol>
Thermal shock (Temperature Cycle)	<ol style="list-style-type: none"> <li>No apparent damage</li> <li>Fulfill the electrical specification after test</li> </ol>	<ol style="list-style-type: none"> <li>One cycle/step 1 : <math>125 \pm 5^\circ\text{C}</math> for 30 min step 2 : <math>-40 \pm 5^\circ\text{C}</math> for 30 min</li> <li>No of cycles : 100</li> <li>Recovery: 1-2 hrs</li> </ol>
Low Temperature Resistance	<ol style="list-style-type: none"> <li>No apparent damage</li> <li>Fulfill the electrical specification after test</li> </ol>	<ol style="list-style-type: none"> <li>Temperature: <math>-40 \pm 5^\circ\text{C}</math></li> <li>Duration: <math>500 \pm 24</math>hrs</li> <li>Recovery: 1-2hrs</li> </ol>

## Soldering Conditions

### ❖ Typical Soldering Profile for Lead-free Process

Reflow Soldering :

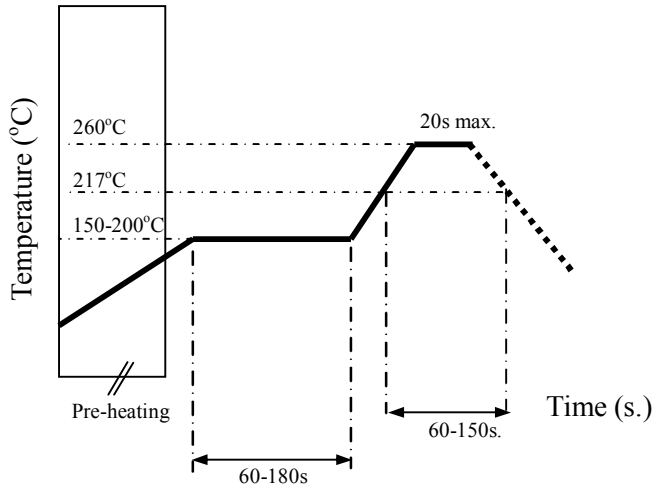

## Notes

❖ The contents of this data sheet are subject to change without notice. Please confirm the specifications and delivery conditions when placing your order.

**Advanced Ceramic X Corp.**

16 Tzu Chiang Road, Hsinchu Industrial District Hsinchu Hsien 303, Taiwan

TEL:886-3-5987008 FAX:886-3-5987001

E-mail: [acx@acxc.com.tw](mailto:acx@acxc.com.tw)

<http://www.acxc.com.tw>