

# DP 3225 Series

Multilayer Chip Diplexers

## Features

- ❖ Monolithic structure including one low-pass and one and-pass filters with loss pole at adjacent passband.

## Applications

- ❖ For LNB applications.



## Specifications

Part Number	Common Port Impedance (ohm)	Low/High band port Impedance (ohm)	Passband (MHz)	Insertion Loss (dB)	Passband VSWR	Ripple (dB)	Attenuation (dB)
DP3225-E1219BC_	75	50	950-1450	2.5 max.	2.0 max.	0.33 max. @ 1425 ~1450MHz (+ 25°C)	22 min. @ 1650~2150 MHz
			1650-2150	2.5 max.	2.0 max.	0.33 max. @ 1650 ~1675MHz (+ 25°C)	22 min. @ 950~1450 MHz

Q'ty/Reel (pcs) : 2,000  
 Operating Temperature Range : -40 ~ +85 °C  
 Storage Temperature Range : +5 ~ +35 °C, Humidity 45~75%RH  
 Storage Period : 12 months max.  
 Power Capacity : 500mW max.

## Part Number

DP   3225   -   E   1219   BC   □   /LF  
 ①   ②   ③   ④   ⑤   ⑥   ⑦

① Type	DP : Diplexer	② Dimensions ( L × W )	3.2 × 2.5 mm
③ Material Code	E	④ Frequency Range	1219 = 1200MHz /1900MHz
⑤ Specification Code	BC	⑥ Packaging	T: Tape & Reel B: Bulk
⑦ Soldering	=lead-containing /LF=lead-free		

## Terminal Configuration

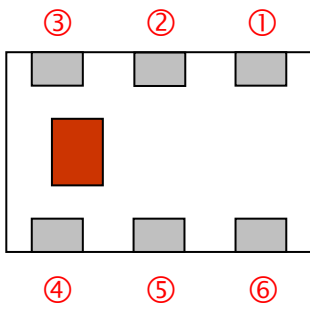

No.	Terminal Name	No.	Terminal Name
①	Higher Freq. Port	④	GND
②	GND	⑤	Common Port
③	Lower Freq. Port	⑥	GND

## Dimensions and Recommended PC Board Pattern

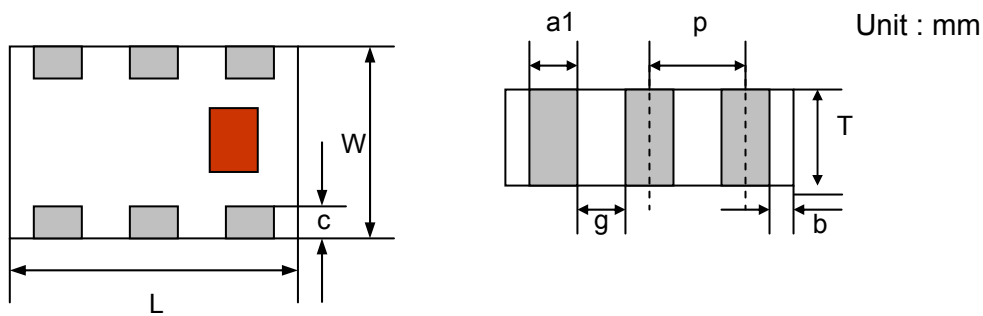

Mark	L	W	T	a1	b	c	g	p
Dimensions	3.2 ± 0.2	2.5 ± 0.2	1.5 ± 0.15	0.55 ± 0.15	0.1min.	0.4+0.1 / -0.2	0.45 ± 0.15	1.0 ± 0.2

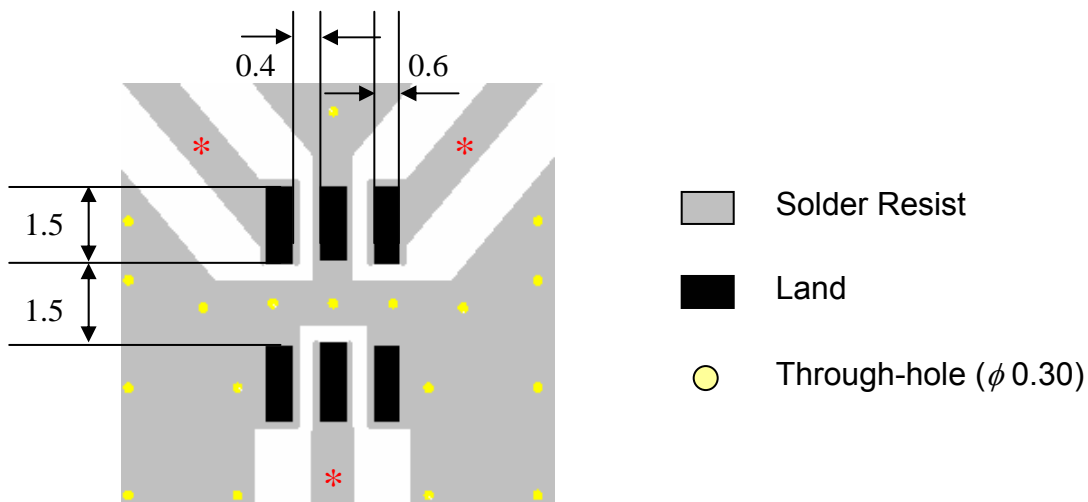

\* Line width should be designed to match 50Ω characteristic impedance, depending on PCB material and thickness.

## Measuring Diagram

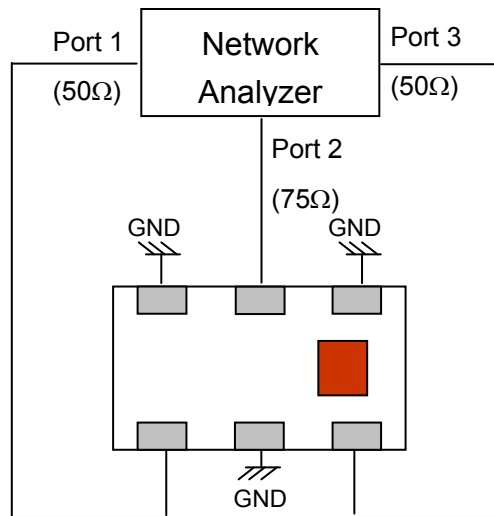

## Typical Electrical Characteristics (T=25°C)

### Attenuation

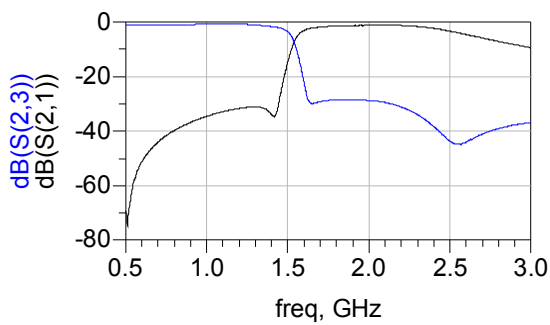

### Return Loss

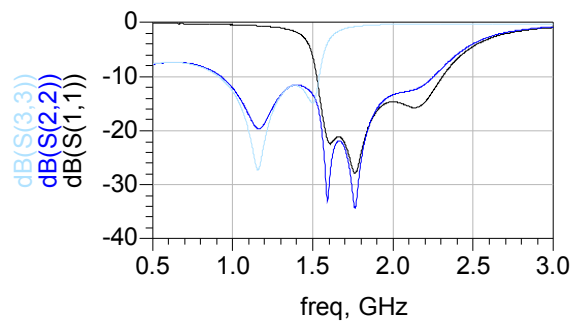

## Notes

- ❖ The contents of this data sheet are subject to change without notice. Please confirm the specifications and delivery conditions when placing your order.

## Taping Specifications

### ❖Tape Dimensions (Unit: mm) & Quantity

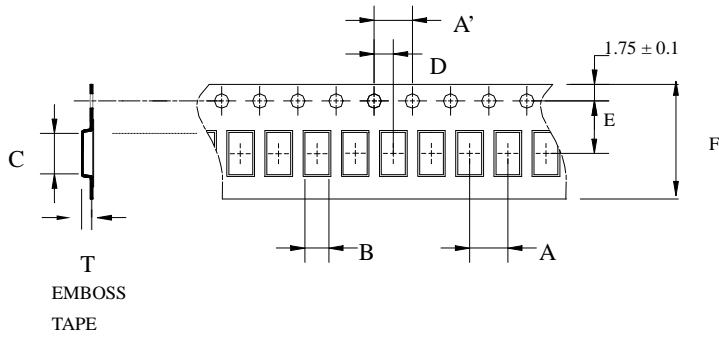

Type	A	A'	B	C	D	E	F	T	Quantity/reel	Tape material
3225	4.0±	4.0±	2.75±	3.45±	2.0±	3.5±	8.0±	1.70±	2,000pcs	Plastic (Embossed)
	0.1	0.1	0.1	0.1	0.1	0.1	0.1	0.10		

### ❖Reel Dimensions (Unit: mm)

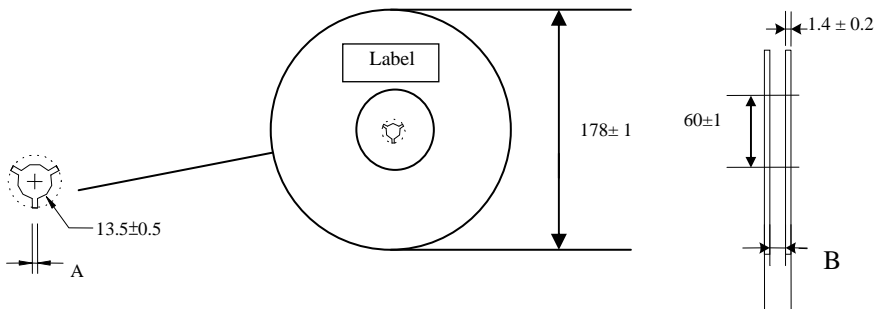

Label: Customer's Name,  
ACX P/N, Q'ty, Date,  
ACX Corp.

Type	A	B
3225	2.3±0.5	9.0±0.3

### ❖Leader and Trailer Tape

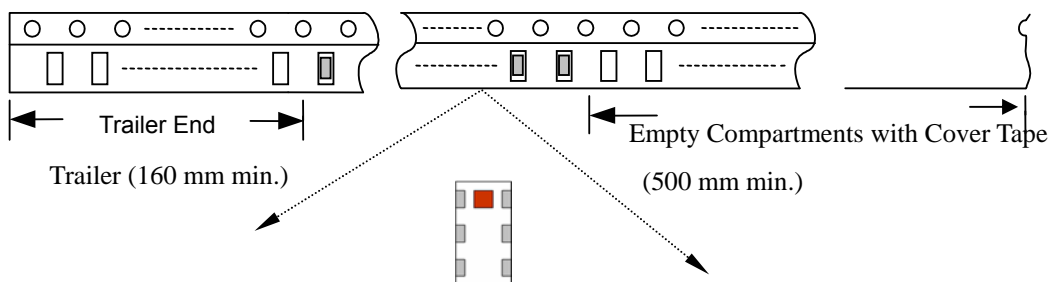

❖ **Peel-off Force**

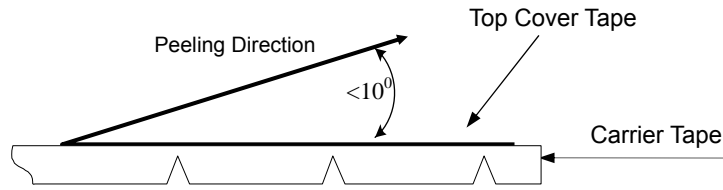

Peel-off force should be in the range of 0.1 – 0.6 N at a peel-off speed of  $300 \pm 10$  mm/min .

❖ **Storage Conditions**

- (1) Temperature: 15 ~35°C , relative humidity (RH): 45~75%.
- (2) Non-corrosive environment.

**Notes**

- ❖ The contents of this data sheet are subject to change without notice. Please confirm the specifications and delivery conditions when placing your order.

## Mechanical & Environmental Characteristics

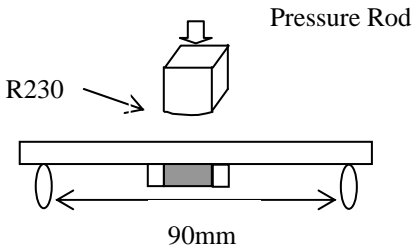
Item	Requirements	Procedure
Solderability	<ol style="list-style-type: none"> <li>No apparent damage</li> <li>More than 95% of the terminal electrode shall be covered with new solder</li> </ol>	<ol style="list-style-type: none"> <li>Preheat: <math>120 \pm 5^\circ\text{C}</math></li> <li>Solder: <math>245 \pm 5^\circ\text{C}</math> for <math>5 \pm 1</math> sec</li> </ol>
Soldering strength (Termination Adhesion)	<ol style="list-style-type: none"> <li>1kg minimum</li> </ol>	<ol style="list-style-type: none"> <li>Solder specimen onto test jig.</li> <li>Apply push force at 0.5mm/s until electrode pads are peeled off or ceramic are broken. Pushing force is applied to longitude direction</li> </ol>
Deflection (Substrate Bending)	<ol style="list-style-type: none"> <li>No apparent damage</li> </ol>	<ol style="list-style-type: none"> <li>Solder specimen onto test jig (FR4, 0.8mm) using the recommend soldering profile.</li> <li>Apply a bending force of 2mm deflection</li> </ol> 
Heat/Humidity Resistance	<ol style="list-style-type: none"> <li>No apparent damage</li> <li>Fulfill the electrical specification after test</li> </ol>	<ol style="list-style-type: none"> <li>Temperature: <math>85 \pm 2^\circ\text{C}</math></li> <li>Humidity: 90% ~ 95% RH</li> <li>Duration: <math>1000 \pm 48</math>hrs</li> <li>Recovery: 1-2hrs</li> </ol>
Thermal shock (Temperature Cycle)	<ol style="list-style-type: none"> <li>No apparent damage</li> <li>Fulfill the electrical specification after test</li> </ol>	<ol style="list-style-type: none"> <li>One cycle/step 1 : <math>125 \pm 5^\circ\text{C}</math> for 30 min step 2 : <math>-40 \pm 5^\circ\text{C}</math> for 30 min</li> <li>No of cycles : 100</li> <li>Recovery: 1-2 hrs</li> </ol>
Low Temperature Resistance	<ol style="list-style-type: none"> <li>No apparent damage</li> <li>Fulfill the electrical specification after test</li> </ol>	<ol style="list-style-type: none"> <li>Temperature: <math>-40 \pm 5^\circ\text{C}</math></li> <li>Duration: <math>500 \pm 24</math>hrs</li> <li>Recovery: 1-2hrs</li> </ol>

## Soldering Conditions

### ❖ Typical Soldering Profile for Lead-free Process

Reflow Soldering :

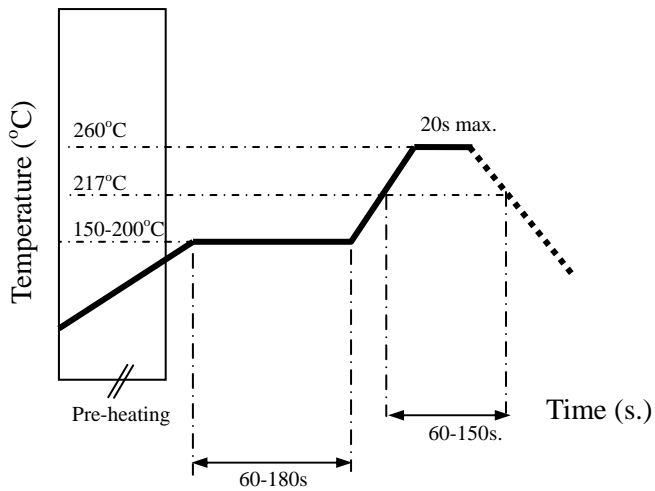

## Notes

❖ The contents of this data sheet are subject to change without notice. Please confirm the specifications and delivery conditions when placing your order.

### **Advanced Ceramic X Corp.**

16 Tzu Chiang Road, Hsinchu Industrial District Hsinchu Hsien 303, Taiwan

TEL:886-3-5987008 FAX:886-3-5987001

E-mail: [acx@acxc.com.tw](mailto:acx@acxc.com.tw)

<http://www.acxc.com.tw>